

Extrusora Rosca Dupla Série SPHS

Catálogo de Equipamento

▲ | Estabilidade ▲ | Confiança



ZhengChang do Brasil Ltda
Estr. Velha Campinas Monte Mor,
Km 01, n 718 Campinas- SP, Brasil
☎ +55 19 3761-3700
✉ contato@calibras.com.br



**ZHENG CHANG
DO BRASIL**

www.zhengchang.com.br



Parâmetros Técnicos

Modelo	SPHS 75x2	SPHS 100x2	SPHS 125x2	SPHS 155x2	SPHS 175x2	
Potência (kW)	75	110/132	200/250	315/355	560/630	
Dosador	SWLT1200(3kW)	SWLT1200(3kW)	SWLT1200(3kW)	SWLT1200(3kW)	SWLT1600(4kW)	
Rosca alimentadora	SWLD14(1.5kW)	SWLD14(1.5kW)	SWLD18(2.2kW)	SWLD23(3kW)	SWLD26(4kW)	
Condicionador	STZD400(11kW)	STZD400(11kW)	STZD400(11kW)	STZD550(15kW)	STZD550(15kW)	
Duplo eixo	STZY280(18.5kW)	STZY280(18.5kW)	STZY390(22kW)	STZY450(30kW)	STZY450(37kW)	
Sistema de corte	YVF2(1.5kW)	YVF2(2.2kW)	YVF2(4kW)	YVF2(5.5kW)	YVF2(7.5kW)	
Capacidade(t/h)	0.8-1.5	2-3	5.5-7.5	10-12	15-16	Ração flutuante*
	0.4-1	1.5-2	4-5	6-8	9-10	Ração submersa*

* Para matriz com furo de $\Phi 4.0\text{mm}$

Desenho Técnico

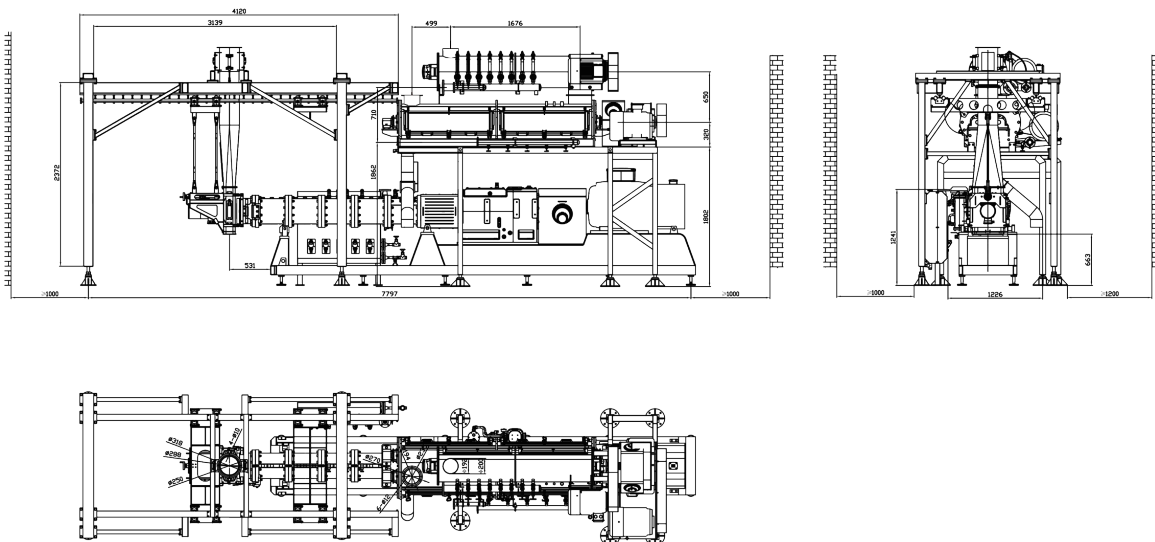

Desenho Técnico da SPHS 100 x 2